

# DC axial fan

Series 400 J 40 x 40 x 25



- **General description:** DC fan with electronically commutated external rotor motor. Commutation electronics completely integrated. Rigid compression curve at low noise.

- **Impeller material:** Fiberglass-reinforced PA plastic

- **Housing material:** Fiberglass-reinforced PBT plastic

## Nominal data

Type	Motor	Voltage VDC	Voltage range VDC	Air flow m³/h	Speed 1/min	Power consumption W	Sound level Bel	Sound pressure level dB(A)	Ambient temperature °C	L10 service life at 20 °C h	L10 service life at max. temp. h	Weight kg
414 JHH	--	24	18 - 27	24	13000	3.6	6.1	46	-20 .. 60	57500	35000	0.050

Subject to modification

## Characteristic: Pressure over air flow

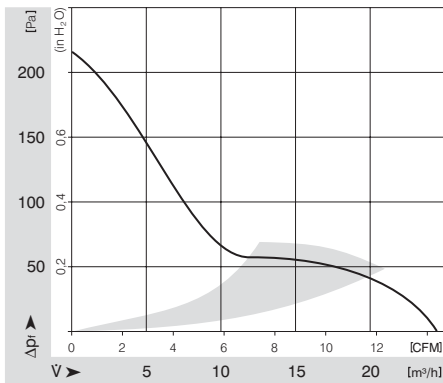

# DC axial fan

Series 400 J 40 x 40 x 25

## Specific drawing

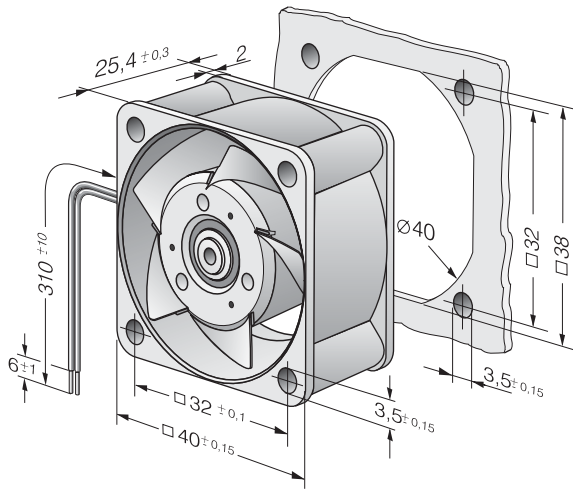

## Technical description

- **General description:** DC fan with electronically commutated external rotor motor. Commutation electronics completely integrated. Rigid compression curve at low noise.
- **Housing material:** Fiberglass-reinforced PBT plastic
- **Direction of rotation:** Left, looking at rotor
- **Electrical connection:** 2 single strands AWG 24, TR 64
- **Locked-rotor protection:** With electronic locked-rotor protection
- **Option:** Speed signal
- **Impeller material:** Fiberglass-reinforced PA plastic
- **Bearings:** Ball bearings
- **Direction of air flow:** Air exhaust over bars
- **Motor protection:** With electronic reverse polarity protection. The fan runs only if the polarity is correct.
- **Approvals:** VDE, CSA, UL, CE

## Contact

### ebm-papst St. Georgen GmbH & Co. KG

Hermann-Papst-Straße 1  
D-78112 St. Georgen  
Phone +49 (0) 7724 / 81-0  
Fax +49 (0) 7724 / 81-1309  
info2@de.ebmpapst.com  
www.ebmpapst.com

# Guard grille

Order No.

LZ29-1

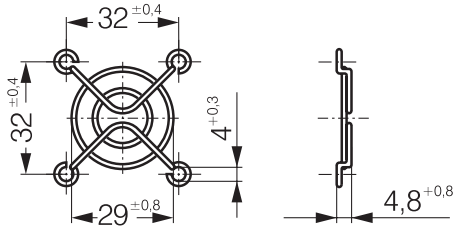

## Technical description

- **General description:** Guard grille in accordance with EN 294

- **Material:** Rust-protected steel wire

## Contact

**ebm-papst St. Georgen GmbH & Co. KG**

Hermann-Papst-Straße 1

D-78112 St. Georgen

Phone +49 (0) 7724 / 81-0

Fax +49 (0) 7724 / 81-1309

info2@de.ebmpapst.com

www.ebmpapst.com