

EC centrifugal fan

forward curved, dual inlet
with housing (flange)

ebm-papst Mulfingen GmbH & Co. KG

Bachmühle 2 · D-74673 Mulfingen

Phone +49 7938 81-0

Fax +49 7938 81-110

info1@de.ebmpapst.com

www.ebmpapst.com

Limited partnership · Headquarters Mulfingen
County court Stuttgart · HRA 590344

General partner Elektrobau Mulfingen GmbH · Headquarters Mulfingen
County court Stuttgart · HRB 590142



Nominal data

Type	D3G146-HQ13-34	
Motor	M3G055-DF	
Phase		1~
Nominal voltage	VAC	230
Nominal voltage range	VAC	200 .. 240
Frequency	Hz	50/60
Type of data definition		ml
Speed	min ⁻¹	2400
Power input	W	230
Current draw	A	1.8
Min. ambient temperature	°C	-25
Max. ambient temperature	°C	50

ml = Max. load · me = Max. efficiency · fa = Running at free air · cs = Customer specs · cu = Customer unit
Subject to alterations

Data according to ErP directive

Installation category	A
Efficiency category	Static
Variable speed drive	Yes
Specific ratio*	1.00

* Specific ratio = $1 + p_{fs} / 100\,000\text{ Pa}$

		Actual	Request 2015
Overall efficiency η_{es}	%	47.9	32.5
Efficiency grade N		59.4	44
Power input P_{ed}	kW	0.15	
Air flow q_v	m ³ /h	505	
Pressure increase p_{fs}	Pa	453	
Speed n	min ⁻¹	2715	

Data definition with optimum efficiency. LU-134808
The ErP data is determined using a motor-impeller combination in a standardised measurement configuration.



EC centrifugal fan

forward curved, dual inlet
with housing (flange)

Technical features

Mass	2.4 kg
Size	146 mm
Surface of rotor	Galvanised
Material of electronics housing	PP plastic
Material of impeller	PP plastic
Housing material	PP plastic
Motor suspension	Motor mounted anti-vibration on both sides
Direction of rotation	Counter-clockwise, seen on rotor
Type of protection	IP 20
Insulation class	"F"
Max. permissible ambient motor temp. (transp./ storage)	+ 80 °C
Min. permissible ambient motor temp. (transp./storage)	- 40 °C
Mounting position	Any
Condensate discharge holes	None, open rotor
Operation mode	S1
Motor bearing	Ball bearing
Technical features	<ul style="list-style-type: none"> - Output 10 VDC, max. 1.1 mA - Tach output - Motor current limit - Soft start - Control input 0-10 VDC / PWM - Control interface with SELV potential safely disconnected from the mains - Over-temperature protected motor
EMC interference immunity	Acc. to EN 61000-6-2 (industrial environment)
EMC interference emission	Acc. to EN 61000-6-4 (industrial environment)
Touch current acc. IEC 60990 (measuring network Fig. 4, TN system)	<= 3.5 mA
Electrical leads	Via terminal box; With plug
Motor protection	Thermal overload protector (TOP) wired internally
Cable exit	Variable
Protection class	I (if protective earth is connected by customer)
Product conforming to standard	EN 60335-1; EN 60335-2-31; CE
Approval	VDE



EC centrifugal fan

forward curved, dual inlet
with housing (flange)

Product drawing

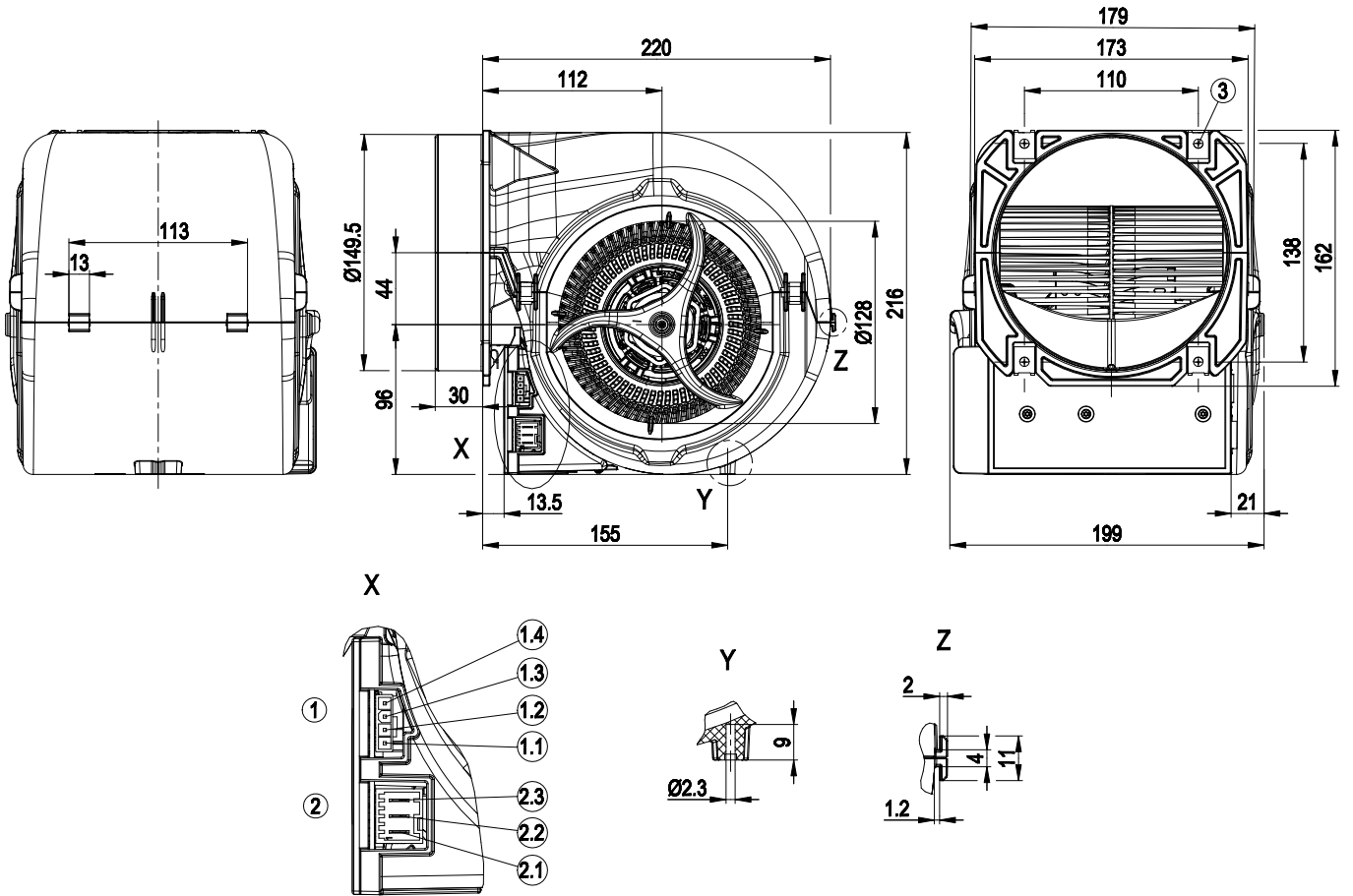

1	Strip Stocko MSLO 7708-004-003-960, pluggable with Stocko EH 705-004-003-960 + RBB 8230.120 Ms
1.1	10V
1.2	Tach
1.3	0-10 V/PWM
1.4	GND
2	Macro module plug connector Stocko MSLO 9404-003-00A-960, pluggable with Stocko MFMP 9761-003-50A-960
2.1	L
2.2	N
2.3	PE
3	4 x sheet metal nut for thread EN ISO 1478-ST4.8 (min. screw length 14.5 mm plus thickness of mounting material)



EC centrifugal fan

forward curved, dual inlet
with housing (flange)

Connection screen

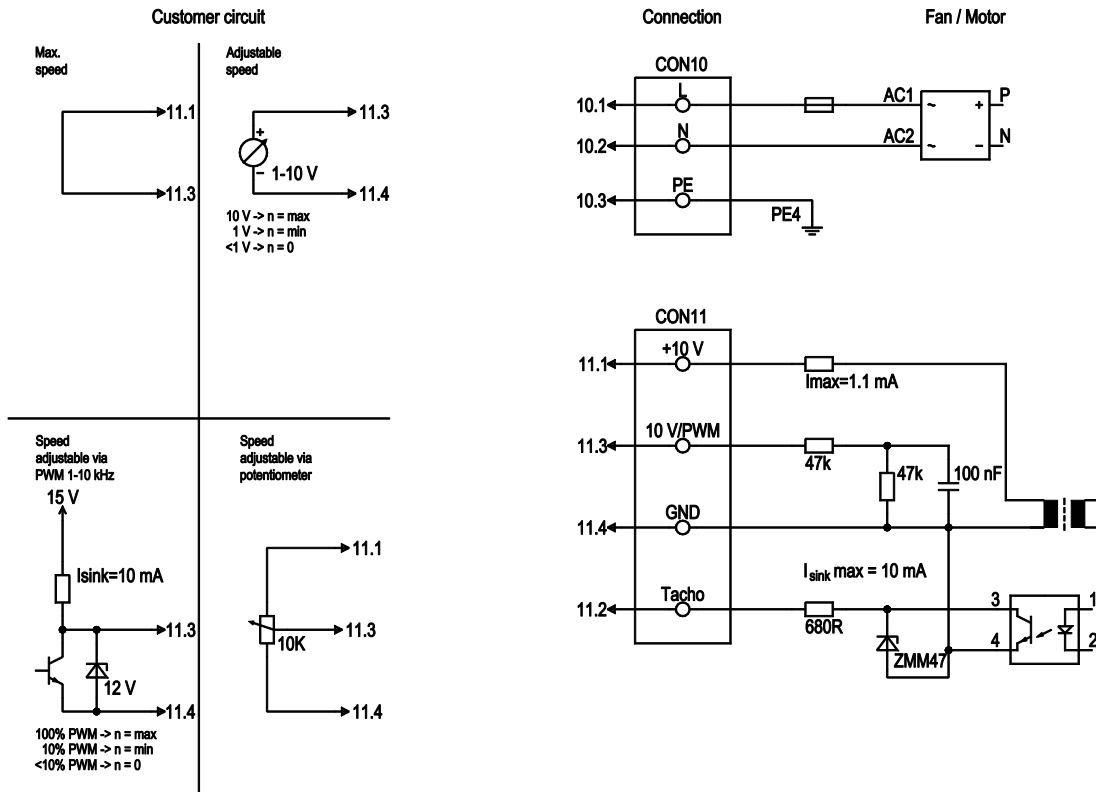

No.	Conn.	Designation	Colour	Function / assignment
CON10	10.1	L	black	Power supply 230 VAC, 50-60 Hz, see type plate for voltage range
CON10	10.2	N		Neutral conductor
CON10	10.3	PE		Protective earth
CON11	11.1	10 V/max. 1.1mA	red	Voltage output 10 V / 1.1 mA, electrically isolated, not short-circuit-proof
CON11	11.2	Tacho		Tach output: Open collector, 1 pulse per revolution, electrically isolated, Isink max = 10 mA
CON11	11.3	0-10 V PWM	yellow	Control input 0-10 V or PWM, electrically isolated
CON11	11.4	GND	blue	GND connection for control interface



Charts: Air flow 50 Hz

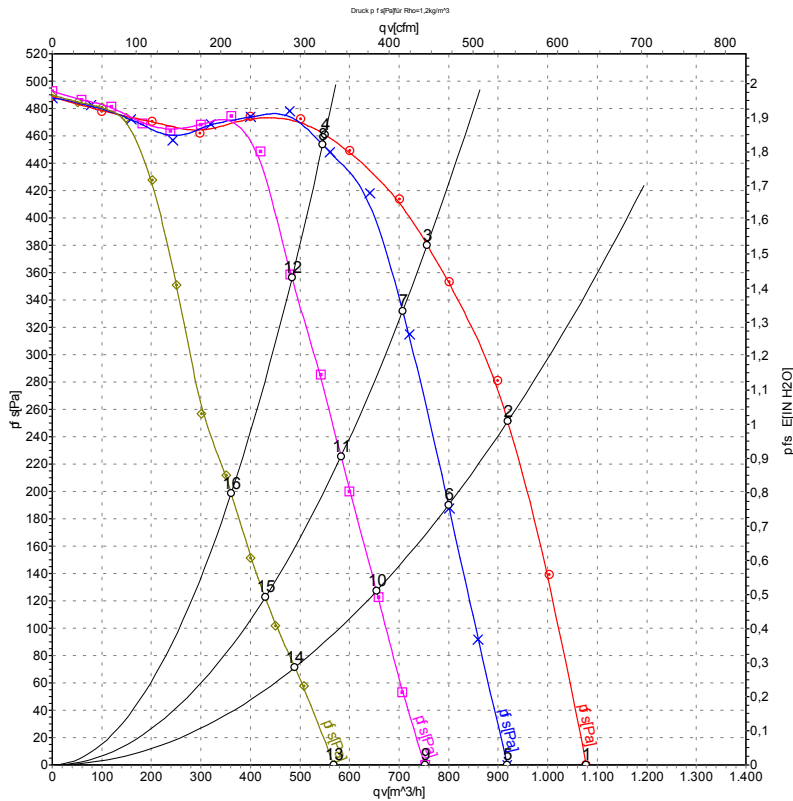

Measurement: LU-134808
 Measurement: LU-132420
 Measurement: LU-132422
 Measurement: LU-132424

Air performance measured as per ISO 5801 Installation category A. For detailed information on the measuring set-up, please contact ebm-papst. Suction-side noise levels: LwA measured as per ISO 13347 / LpA measured with 1m distance to fan axis. The values given are valid under the measuring conditions mentioned above and may vary according to the actual installation situation. With any deviation from the standard set-up, the specific values have to be checked and reviewed with the unit installed.

Measured values

	U	f	n	P _{ed}	I	LpA _{in}	LwA _{in}	qv	p _{fs}
	V	Hz	min ⁻¹	W	A	dB(A)	dB(A)	m ³ /h	Pa
1	230	50	1790	189	1.47	62	74	1080	0
2	230	50	2400	230	1.80	62	73	920	250
3	230	50	2535	206	1.61	61	72	755	380
4	230	50	2705	164	1.30	61	72	550	460
5	230	50	1535	118	0.97			920	0
6	230	50	2040	154	1.21			800	191
7	230	50	2395	175	1.38			705	333
8	230	50	2695	169	1.33			545	454
9	230	50	1265	66	0.57			750	0
10	230	50	1675	85	0.71			655	128
11	230	50	1975	98	0.82			585	225
12	230	50	2380	118	0.96			485	354
13	230	50	970	29	0.27			570	0
14	230	50	1275	38	0.34			490	72
15	230	50	1490	43	0.37			430	122
16	230	50	1800	52	0.44			360	199

U = Supply voltage · f = Frequency · n = Speed · P_{ed} = Power input · I = Current draw · LpA_{in} = Sound pressure level inlet side · LwA_{in} = Sound power level inlet side · qv = Air flow
 p_{fs} = Pressure increase

