

CX10 & CMF Commercial ceiling mounted fans



The Range

The CX10 and CMF are flush mounted ceiling extract fan units, which come complete with an intake grille finished in white. The CX10 has an integral duct connection spigot (203mmØ), whilst the CMF units have side entry spigots (CMF171/241 - 102mm Ø & CMF271 - 150mm Ø) plenum box. Applications include kitchens, larger utility rooms, pub bars, schools and shops.

Key Features

- Four models available - CX10, CMF171, CMF241 & CMF271
- Operated by remote sensor switches
- Conforms to Building Regulations Part F1
- Complete with integral fly guard

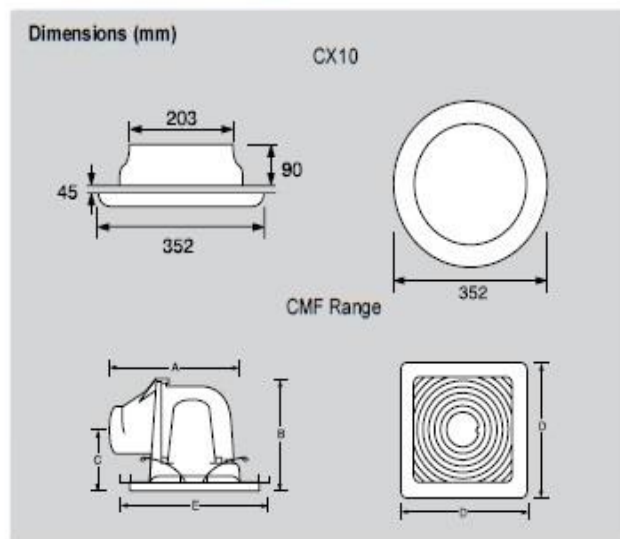

Models

CX10 **Ref. 90209AB**
Single speed axial flush mounted extract ceiling fan with stylish circular flush design | Unit comes complete with integral finger-guard and fly screen | Lightweight two piece construction | Moulded pre-balanced axial bladed impeller | Suitable for steam and condensation applications | Vertical spigot with 200mm diameter connection | Operated by remote switch or sensor (not supplied)

CMF 171 **Ref. 89955AW**

CMF 241 **Ref. 89956AW**

CMF 271 **Ref. 89957AW**
Flush mounted extract ceiling fans | High performance single speed centrifugal pressure developing motor/fan/scroll assemblies | Stylish square grille design with integral finger-guard | Lightweight two piece construction with horizontal spigot outlet | Cassette design allows ducting to be installed prior to the fan itself

Accessories

CXS Back Draught Shutter **Ref. 00150AB**
CXS (for CX10)
200mm

TDK8 Termination Duct Kit **Ref. 92789AA**
TDK8 (for CX10)
200mm

Ancillaries See pages 72-87

Model	Dimensions (mm)				
	A	B	C	D	E
CMF171	277	226	123	230	240
CMF241	343	260	133	290	319
CMF271	420	318	133	320	350

Product Selector	CX10	CMF171	CMF241	CMF271
Reference number	90209AB	89955AW	89956AW	89957AW
Electrical power rating (W)	34	30	33	48
Hole diameter (mm)	300	185 x 185	248 x 248	273 x 273
Ducting size (mm)	200	102	102	150
Weight (kg)	1.8	2.7	3.8	6.9
UK Guarantee (years)	2	2	2	2
Extract performance (FID, m ³ /h)	329	63	146	286
Extract performance (FID, l/s)	91	18	41	79
Sound pressure level (dB(A))@3m	44	38	41	41