

"FPF15KG" SERIES FAN FILTER

Description: **Fan Filter 115/230/400 Va.c.**



Type of material:	ABS/PC alloy
Standard color:	RAL 7032, RAL 7035 and RAL 9005 - other colors on request
Protection degree:	IP54, according to EN 60529 Std Nema Type 12, according to UL 508 Std
Fixing system:	by elastic hooks, otherwise by four 4.8 mm self-threading screws
Plate thickness:	from 1.5 mm to 2.2 mm
Storage temperature:	from -30°C to +75°C
Motor Lifetime L10 at 40°C (approx.):	45,000 h
Working class of capacitor:	class B
Motor protection:	thermal
Electrical connection:	by terminal block 3 poles L-N-PE or 4 poles L1-L2-L3-PE
Earth connection:	(by terminal block, PE pole)
Appliance class:	Class I
Type of filter media:	thermo-linked progressive structure synthetic fibre
Filtering class:	class G3, according to EN 779
Degree of separation:	85% - DIN 24185
Dust retention capacity:	600 g/m ²
Note:	filter media is washable for about 10 times
Weight:	3.5 Kg
Approvals:	CE

technical drawing

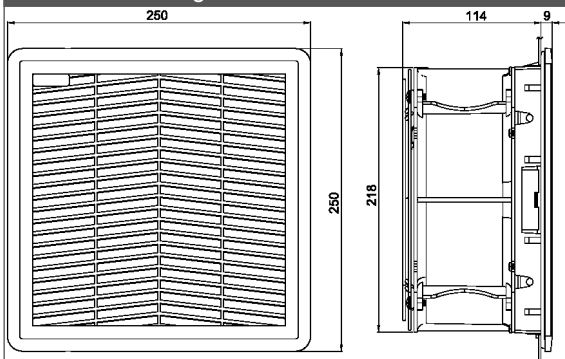

mounting cut-out

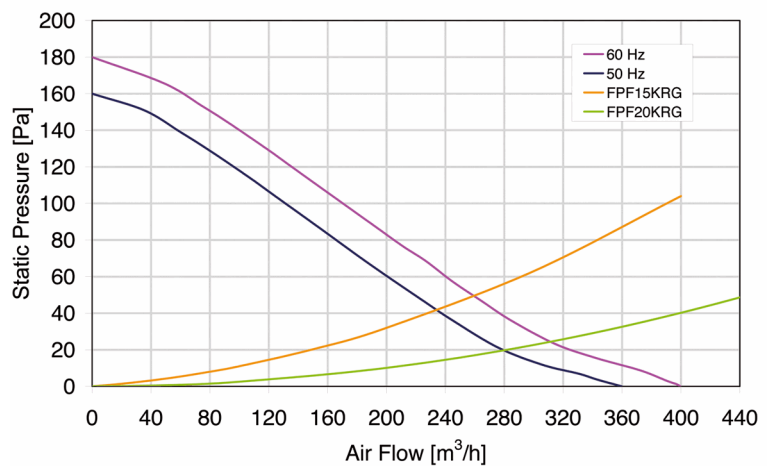
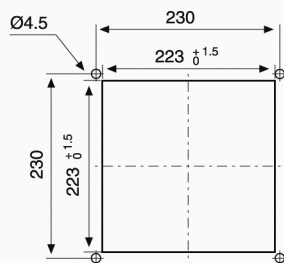

Model	Voltage	Frequency	Rated Current	Rated Power	Max Air Flow**	Static Pressure	Fan Noise	Rated Temp. Range	Approvals
	(V)	(Hz)	(A)	(W)	(m3/h)	(Pa)	[db(A)]	(°C)	
FPF15KGR115BE-120	115 V a.c.	50/60	0.54/0.65	50/64	360/400	160/180	66.0/69.2	-10 + +55	CE
FPF15KGR115BER-120	115 V a.c.	50/60	0.54/0.65	50/64	360/400	160/180	66.0/69.2	-10 + +55	CE
FPF15KGU115BE-120	115 V a.c.	50/60	0.54/0.65	50/64	360/400	160/180	66,0/69,2	-10 + +55	CE
FPF15KGU115BER-120	115 V a.c.	50/60	0.54/0.65	50/64	360/400	160/180	6600/69.2	-10 + +55	CE
FPF15KG*230BE-120	230 V a.c.	50/60	0.300/0.382	67/87	360/400	160/180	63.3/68.1	-10 + +50	CE
FPF15KG*230BER-120	230 V a.c.	50/60	0.300/0.382	67/87	360/400	160/180	63.3/68.1	-10 + +50	CE
FPF15KG*400TBE-120	400 V a.c.	50/60	0.140/0.130	71/93	360/400	160/180	69.8/72.7	-10 + +55	CE
FPF15KGU400TBER-120	400 V a.c.	50/60	0.140/0.130	71/93	360/400	160/180	69.8/72.7	-10 + +55	CE

* U = RAL 7035 R = RAL 7032 N = RAL 9005 **data with uncertainty of 15%